

FIRE SAFE DESIGN TO API 607; TEST AND INSPECTION TO API 598; VALVES ARE IN ACCORDANCE WITH NACE MR-01-75 LATEST REV  
 All drawings are subject to copyright, reproduction only with express permission of Edmund Valve Company (1965) Ltd. Subject to updating and revision.

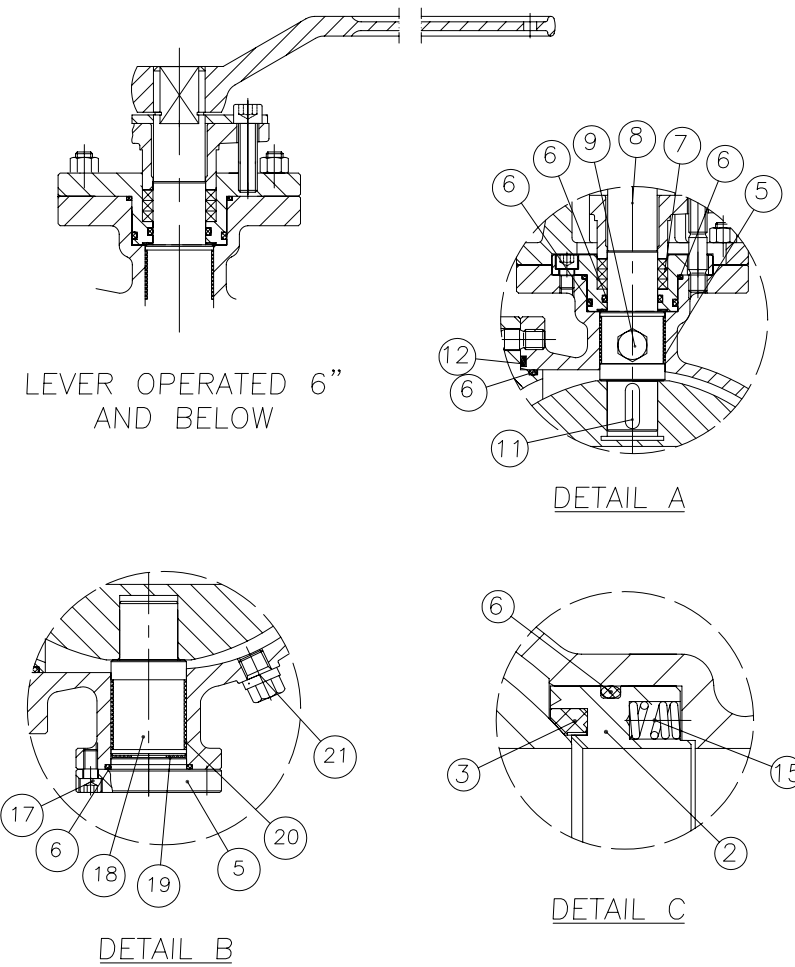

NO	PART NAME	MATERIAL	NOTES
21	DRAIN VALVE	AISI 1020+Zn	
20	BOTTOM COVER	ASTM A216 WCB/A105	
19	LOWER THRUST WASHER	PTFE	
18	FIXED SPINDLE	A182 F316	
17	SCREW	A193 GR.B7M	
16	BONNET/CLOSURE	ASTM A216 WCB	
15	SPRING	AISI 304 SS	
14	STUD	A193 GR.B7M	
13	NUTS	A194 GR.2HM	
12	GASKET	SS316+GRAPHITE	
11	KEY	A182 F316	
10	SUPPORT	ASTM A216 WCB	
9	VENT VALVE	AISI 1020+Zn	
8	STEM	A182 F316	
7	PACKING	PTFE	
6	O-RING	VITON	
5	SLIDING BEARING	PTFE/STAINLESS STEEL	
4	BALL	AISI 316 SS	
3	SEAT	NYLON	
2	SEAT CARRIER	A182 F316	
1	BODY	ASTM A216 WCB	

Size	A			B	B1	C
	RF	RTJ	WE			
2"	368	371	368	51	51	216
3"	381	384	381	77	77	241
4"	457	460	457	102	102	292
6"	610	613	610	152	152	381
8"	737	740	737	203	203	470
10"	838	841	838	254	254	544.5
12"	965	968	965	305	305	610
14"	1029	1038	1029	324	324	641.5
16"	1130	1140	1130	375	375	705
18"	1219	1232	1219	425	425	785
20"	1321	1333	1321	473	473	858
24"	1549	1568	1549	571.5	571.5	1042

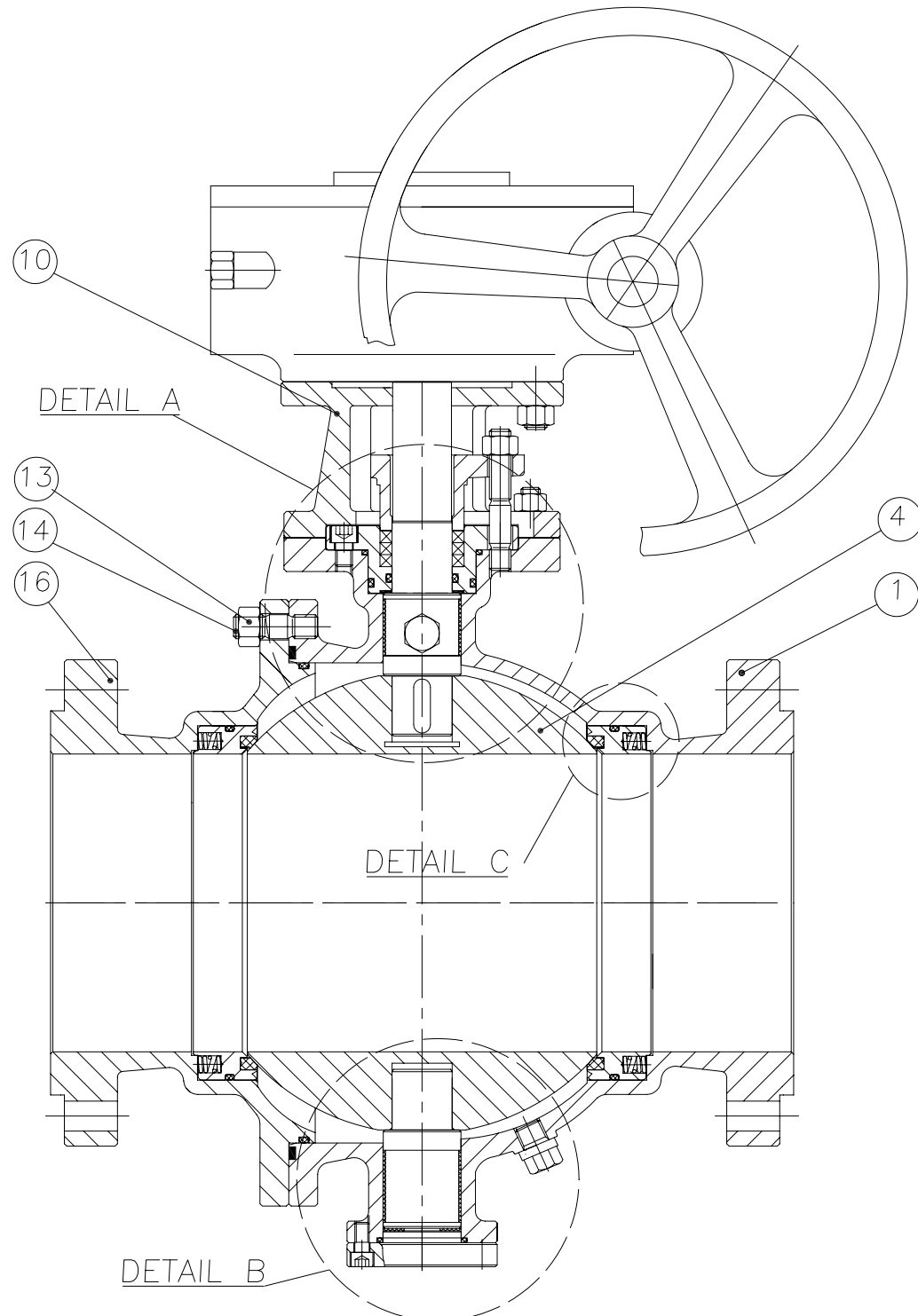
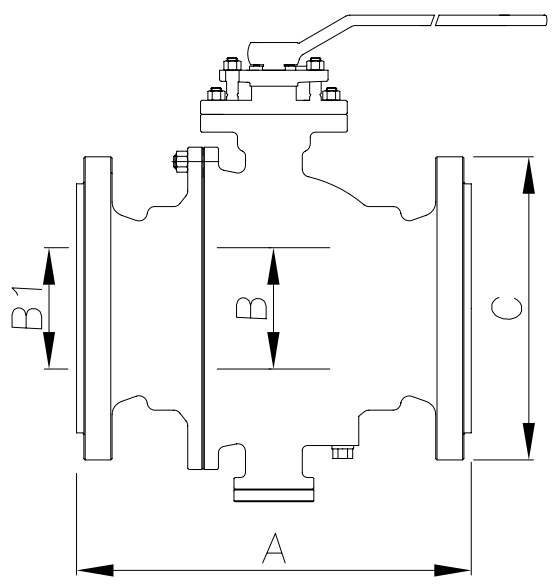

DESIGN CODE	API 6D/ANSI B16.34	TEST PRESSURES		
FACE TO FACE DIMENSIONS	ASME B16.10	BODY	229.8	Barg
ENDS FLANGES DIMENSIONS	ASME B16.5	SEAT	168.52	Barg
TESTING CODE	API 598	SEAT - AIR	6.0	Barg

REV	DATE	DESCRIPTION	BY	CHK	APP	SCALE:		
						DRAWN	DM	DATE
						CHECKED	SMN	DATE
						APPROVED	AW	DATE

DRAWING TITLE:  
API 6D, CARBON STEEL CLASS 900  
TRUNNION MOUNTED, RF, BALL VALVE

CLIENT: . . . . .

VENDOR PO REF: . . . . .

EVC REF: . . . . .



**Edmund**  
VALVE COMPANY (1965) LTD

CAD. No.	DRAWING NUMBER: 120021	REV
AREA No. 1	FACILITY	TYPE
SEQ. No.	SHT. No.	01