

8	BOLTING	ASTM A193 B7M/ A194 Gr.2HM	ASTM A193 B8M/ A194 Gr.8M	
7	GASKET	SS304+GRAPHITE		
6	LOWER THRUST WASHER	PTFE		
5	STEM	ASTM A182 F316		
4	STEM SEAL	PTFE		
3	BALL	ASTM A351 CF8M		
2	SEAT RING	RPTFE		
1	BODY/CLOSURE	ASTM A216 WCB/ ASTM A352 LCB	ASTM A351 CF8M	
NO	PART NAME	MATERIAL		NOTES

NOTES	
1	
2	
3	

Size	A	B	B1	C
1/2"x3/8"	140	10	12	95
3/4x1/2"	152	12	20	120
1x3/4"	165	20	25	125
1 1/2x1"	191	25	38	155
2"x1 1/2"	216	38	51	165
3"x2"	283	51	77	210
4"x3"	305	77	102	254
6"x4"	403	102	152	318
8"x6"	502	152	203	381
10"x8"	568	203	254	445

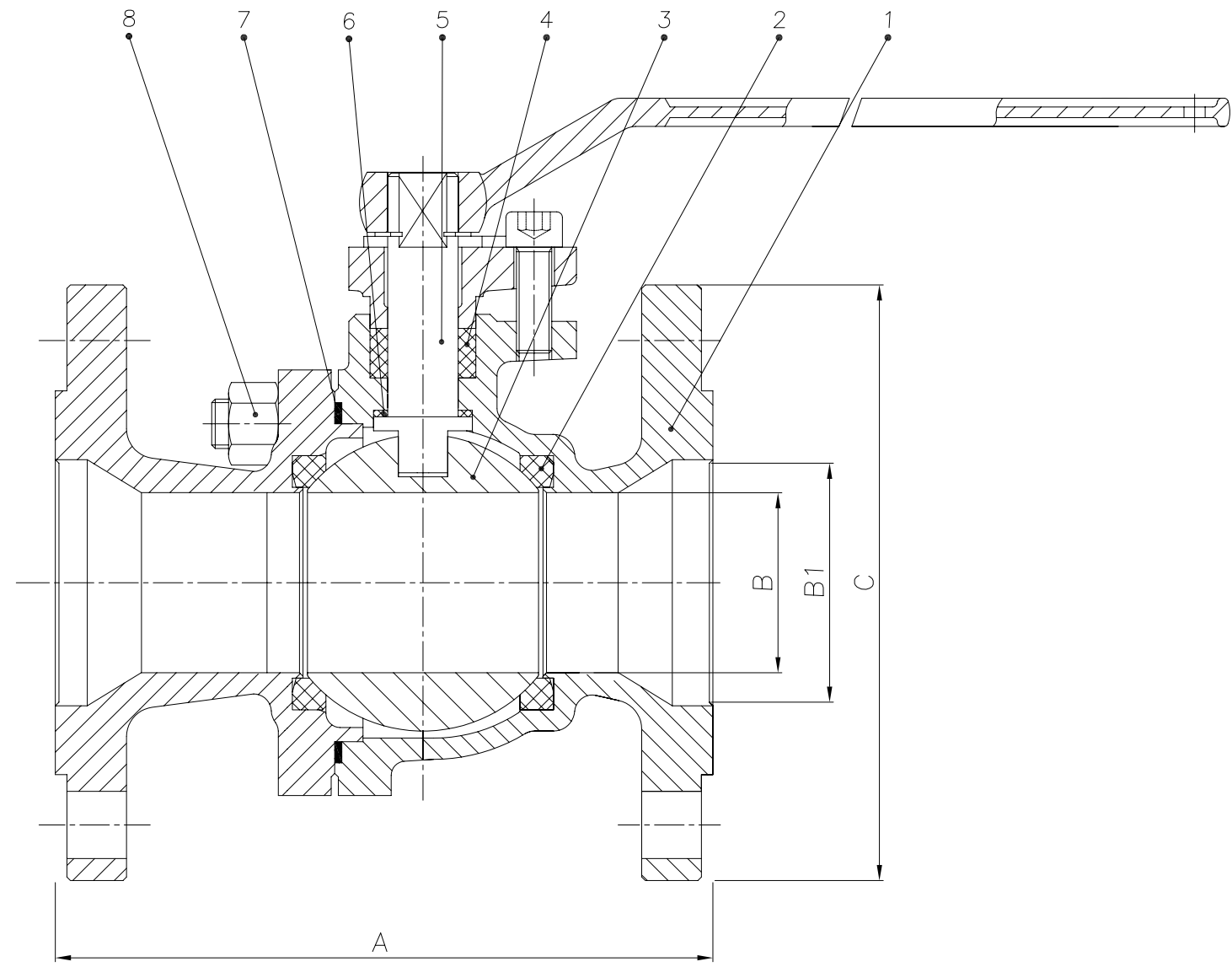

DESIGN CODE	API 6D/ANSI B16.34	TEST PRESSURES		
FACE TO FACE DIMENSIONS	ASME B16.10	BODY	76.6	Barg
ENDS FLANGES DIMENSIONS	ASME B16.5	SEAT	56.2	Barg
TESTING CODE	API 598	SEAT - AIR	6.0	Barg

REV	DATE	DESCRIPTION	BY	CHK	APP	SCALE:		
						DRAWN	DM	DATE: 16/02/2012
						CHECKED	SMN	DATE
						APPROVED	AW	DATE

DRAWING TITLE:
API 6D, CARBON STEEL CLASS 300
FLOATING BALL, RF, RB, BALL VALVE

CLIENT:

VENDOR PO REF:

EVC REF:

CAD. No. | DRAWING NUMBER: 1200011 | REV
AREA No. 1 | FACILITY | TYPE | SEQ. No. | SHT. No. | 01

All drawings are subject to copyright, reproduction only with express permission of Edmund Valve Company (1965) Ltd. Subject to updating and revision. All Edmund valves drawings are product specific, it is the clients responsibility to ensure suitability for service. Materials, design and dimensions subject to contract.

MATERIALS TO MAKE MR0175, LATEST EDITION (WETTED PARTS)